

GENT
by Honeywell

Section 3:

**Fire Detection & Alarm
Design**



3: FIRE DETECTION & ALARM DESIGN

Introduction

GENT
by Honeywell

This guide provides a basic overview to anyone involved in the design or installation of a fire detection system. It will identify the current legislative requirements as well as clarify the responsibilities placed on the three key roles involved with the provision of a new system, namely the Designer, Installer and Commissioning Engineer, as well as remind the End User or Owner/Occupier what part they play in ensuring that the best possible system is supplied to protect life and property from fire.

It is important that everyone involved is conversant with the current British Standard Codes of Practice BS 5839-1:2002 for general buildings and BS 5839-6:2004 for dwellings including those of multiple occupancy. The Installer should also be conversant with the British Standard relating to general wiring BS 7671.

This guide, which has been prepared by Gent, one of the UK's largest manufacturers of fire detection systems, is intended to offer practical advice and is not a substitute for any of the standards or legislation referred to.

Legal elements

- Regulatory Reform Fire Safety Order 2004 (draft)
- Disability Discrimination Act 1995 part III (October 2004)
- Building Regulation Approved Document B**
- Building Regulation Approved Document M

All these documents in some way affect what is included in the system. However the Owner/Occupier is ultimately responsible for the level of protection provided.

It is recommended that the Owner/Occupier carries out a Fire Risk Assessment to identify the level of protection required i.e. one of the categories detailed within BS 5839-1:2002 (L1,L2,L3,L4,L5,M,P1 or P2). The full responsibilities of the Owner/Occupier are detailed within the new Regulatory Reform Fire Safety Order* (RRO) which will replace the majority of existing laws within the UK during 2005/6.

* *Note the RRO, at time of press, was expected to take effect in England & Wales in October 2005 whilst Scotland and NI have their own time frame.*

** *Approved doc B due to be amended in line with RRO in 2005.*

Any design should be prepared by a competent individual/organisation, who has consulted all interested parties and created a set of drawings, a specification, a cause & effect or fire plan, a list of Variations and completed a G1 Design certificate, detailed within BS 5839-1:2002.

If designs are undertaken without this research being carried out, the fire detection system is unlikely to comply with the legal requirements. This could result in prosecution of the parties involved within the supply chain as well as the Owner/Occupier.

WARNING: Anyone who takes on the responsibility for design will do so at their own risk and design liability insurance is advisable.

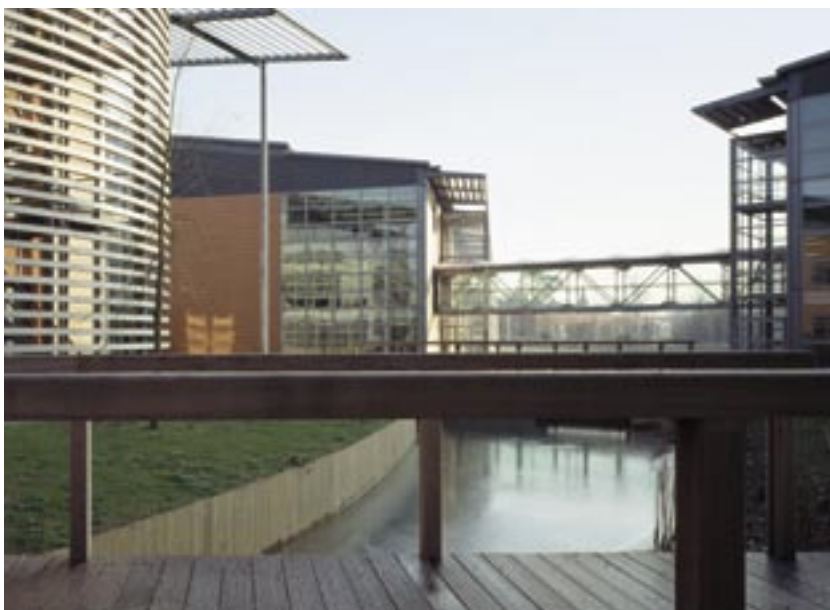

The Designers' responsibilities:

- Agree the level of protection or category with Owner/Occupier
- Justify any Variations and document reasons
- Detail the detection & alarm zones
- Prepare specification and drawings including;
 - Siting of manual call points
 - Siting of point type heat and smoke detectors
 - Siting of beam detectors
 - Siting of any other forms of detection
- Specify type of cable for each circuit
- Specify type of system and equipment
- Include detail for on/off site links with other equipment
- Take into account the risk of false alarms – use the Gent sensor application guide at the back of this section
- Allow for correct level of sounders and visual alarms
- Prepare a fire plan or cause and effect chart
- Sign a G1 design certificate

Note BS 5839-1:2002 recommends that a fire detection system is designed by a competent person, who takes responsibility for completing the design and signing off a 'Design certificate' G1. This should not be confused with other certificates relating to Installation G2 and Commissioning G3, that are completed by the parties responsible for those parts.

Also if the contract allows, it is suggested that the Designer witness tests the completed system to ensure the original design is still appropriate – the Design certificate can then be completed after any amendments have been included.



3: FIRE DETECTION & ALARM DESIGN

System Design

GENT
by Honeywell

Design Stage 1 Talk to the interested parties to decide on the level of protection or category and agree Variations

The importance of pre-design planning cannot be overstated. Many parties are likely to have an interest in what the fire detection is expected to do. Ultimately it is up to the Owner/Occupier, who is responsible by law, to make the final decision on the level of protection provided for a particular building.

In most circumstances the Owner/Occupier will appoint a competent Designer to carry out this work and take liability for the design as a whole.

The nominated Designer is expected to consult the following organisations:

- The User or Facilities Manager
- The Building Control Officer
- The Health and Safety Executive
- The Insurer
- The Local Fire and Rescue Service
- A specialist fire alarm system supplier

Issues to be covered by the designer should include:

- The Fire Risk Assessment demands
- The requirements necessary to comply with the Regulatory Reform (Fire Safety) Order (RRO) 2004, the Disability Discrimination Act (DDA) 1995 and Building Regulations Approved Documents B & M
- The prime purpose of the system (Property or life protection or both)
- The level of protection suggested by the interested parties. (Category P1 or P2, M or L1 L2 L3 L4 or L5)
- The list of Variations identified by the interested parties

Determine the System Category or Level of Protection

Systems designed for Protection of Property only, fall into two classifications P1 or P2.

The objective of a Category P1 is to provide the earliest possible warning of a fire to minimise the time between ignition and the arrival of the fire fighters.

P1 is designed to protect the whole building whilst P2 is installed in defined parts of the building only, which may have an extraordinary high risk or hazard.

Life protection on the other hand will often depend on the number of people accessing a particular building and depending on the variations, the systems can range from simple Type M to L1 categories, these being detailed in the diagrams on this page.

These diagrams show a typical building with a number of escape routes, side rooms and open plan areas used for escape.

A **Category M** system requires manual call points on all exits as well as corridors where persons are not expected to walk more than 45m (see Design Stage 3) to operate one.

Category L5, designed for buildings that have a particular risk identified which warrants some special attention. For example if there is an area of high risk which is considered worthy of having some automatic detection but a manual system is also needed, then this will be termed as L5/M.

Category L4 provides detection within the escape routes only, whereas L3 not only covers these areas but all rooms leading onto the escape route. The reasoning behind this is to alert people of the danger prior to the corridor becoming "Smoke logged" so people can escape safely.

L2 is a further enhancement of protection with all the areas covered by an L3 category as well as all high risk areas such as boiler rooms etc.

L1 provides protection throughout the building, and also where Property Protection is the prime reason for the system (this allows for a choice between the P1 or P2 categories).

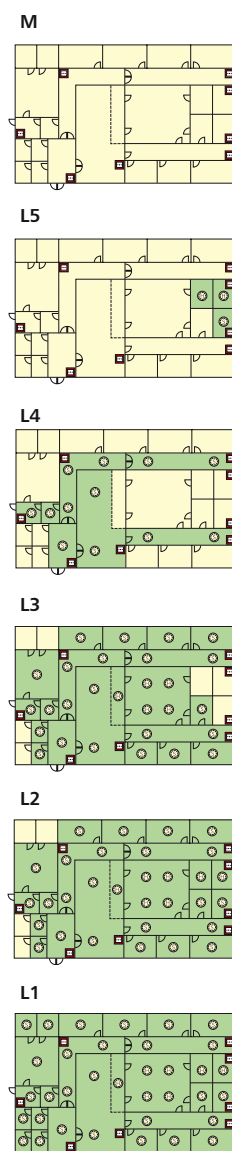

Design Stage 2 Detection and Alarm Zones

Generally a building is broken down into smaller compartments to enable the fire fighters to locate the fire as quickly as possible. Even if the system is addressable it is still considered beneficial to have a separate 'at a glance' indication of the location of the fire. These compartments of a building are called detection zones, which need to comply with the following criteria.

Detection Zones

- A detection zone should cover no more than 1 storey, unless total floor area is less than 300m². Voids in the same fire compartment should be included in the same floor zone. The maximum floor area of a zone should not be greater than 2,000m², except for some large open plan areas incorporating manual call points only, which can be extended to 10,000m².
- The maximum search distance for the fire fighters to see the seat of the fire within a zone should not exceed 60m assuming the route taken is the worst possible option.
- Vertical structures such as stairwells, liftwells etc should be considered as separate zones.
- A manual call point within a staircase should be connected to the zone associated with that floor and ideally be mounted on the accommodation side of the corridor exit. Automatic sensors on the stairwell remain as part of the stairwell detection zone.

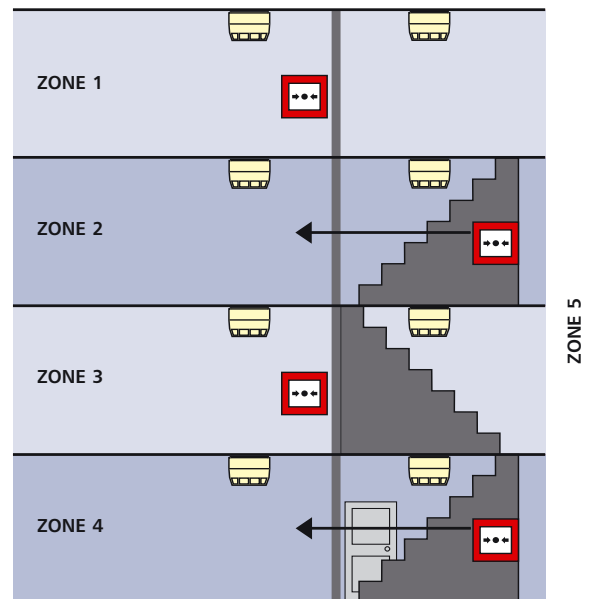

Alarm Zones

An alarm zone is clearly defined within the standard but generally is an area of the building coinciding with the fire compartment boundaries. There must be a clear break between these alarm zones to ensure alert and evacuation messages are not overheard from adjacent areas.

The only other criteria is that an alarm zone may consist of a number of detection zones but not vice versa.

Alarm zones are only required when phased or staged evacuation is required. It is therefore important that care should be taken to ensure only one message is heard at any one time particularly where two alarm zones are attached.

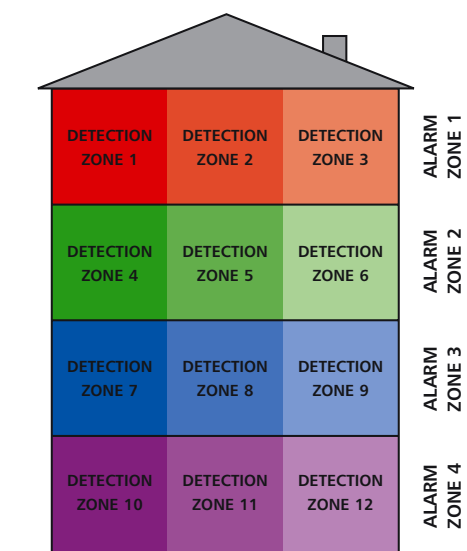

3: FIRE DETECTION & ALARM DESIGN

GENT
by Honeywell

System Design

Design Stage 3 Siting of Manual Call Points

All manual call points, whatever the system, should comply to BS EN54-11 single action Type A version only and should be located as follows:

- On all storey exits and all exits to open air irrespective of whether they are designated fire exits
- Nobody should travel more than 45 metres to reach one, except if the exit routes are undefined in which case the direct line distance should not exceed 30 metres
- The above distances to be reduced to 25 and 16 metres respectively, if there are persons with limited mobility or there is a likelihood of rapid fire development
- In all areas with potential high fire risk such as kitchens etc
- Where phased evacuation is planned, call points will need to be sited on all exits from a particular zone
- 1.4 metres + or – 200mm above the floor
- Call points fitted with protective hinged covers for whatever reason should be listed as a Variation

Note: In order to comply with the requirements of Building Regulations Approved Document M, which requires electrical switches including manual call points to be mounted at between 1M + or – 200mm on wheel chair access routes, these should be listed as a Variation on the certificate as BS requires MCP's to be mounted at 1.4M + or – 200mm.

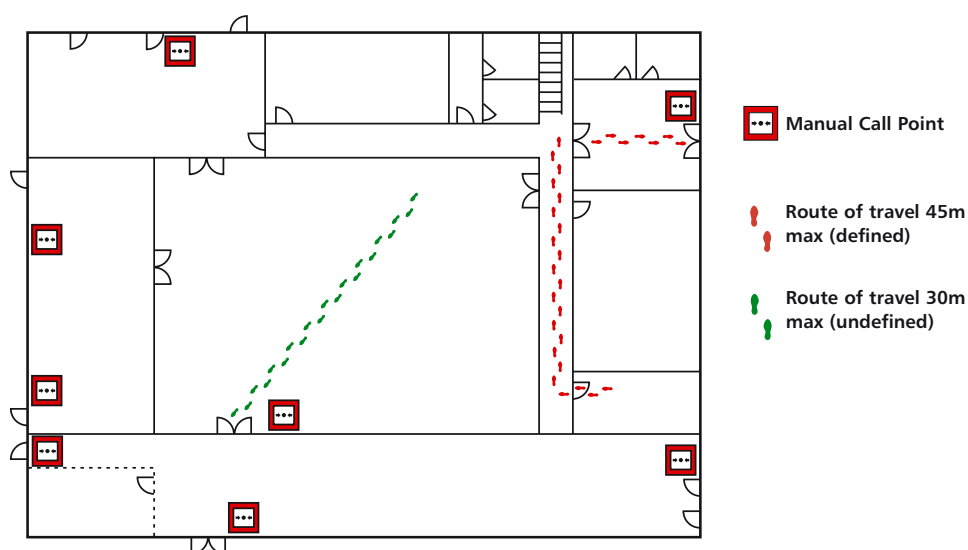

Design Stage 4 Selection and siting of Sensors

For further advice please refer to clauses 21 & 22 of BS 5839-1:2002

The objective is to select the correct sensor for the appropriate application, to provide the earliest warning of fire without the risk of a false alarm.

It is therefore worth trying to visualise the type of fire that is likely to occur in a particular room or area and also to familiarise oneself with the application and the risks that could give rise to a false alarm.

It should also be remembered that a Vigilon system can incorporate a whole range of different sensors using S-Quad multi-sensors. These can be set up for different applications and can be switched from 'state to state' should particular risks be present for short periods of time. This is achieved by selecting the 'enable/disable' software within the standard panel software. At the end of this section is a full application guide for all sensors including the latest S-Quad multi-sensor with a range of selectable 'states' for common applications and risks.

Heat sensors complying to BS EN54-5

Vigilon with the S-Quad heat sensor has a number of pre-programmed 'states' that comply with the requirements of the European standard.

Each state has its preferred use as described in the Sensor Application Guide and incorporates two types of heat sensing element. One can be described as fixed temperature whilst the other is known as a rate of rise element. These elements have a broad range of application specific operating states that will respond quickly in the event of fire without risking a false alarm. See the Sensor Application Guide at the back of this section for specific advice on which state is recommended for a particular application. For example;

The default state for the S-Quad heat sensor is Grade A1 (state 0) which has a fixed temperature operating point of $59.5^{\circ} + \text{or} - 5.5^{\circ} \text{C}$. with a 'normal' rate of rise element, the current 'full list' of states provided by S-Quad and Vigilon are:-

S-QUAD HEAT SENSOR	GRADE	FIXED TEMP. RANGE	RATE OF RISE
State 0	A1	$59.5 + \text{or} - 5.5^{\circ}\text{C}$	Normal sensitivity
State 5	B	$77 + \text{or} - 8^{\circ}\text{C}$	Less sensitivity
State 6	BS	$77 + \text{or} - 8^{\circ}\text{C}$	OFF
State 15		OFF	OFF

Heat detector spacing (under flat horizontal ceiling)

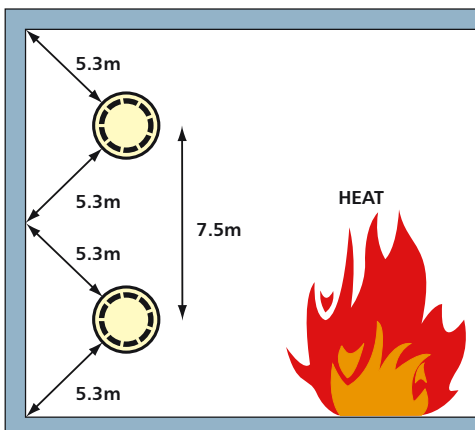

3: FIRE DETECTION & ALARM DESIGN

GENT
by Honeywell

System Design

Smoke sensors complying to BS EN54-7

Traditionally, 'point' type smoke sensors have fallen into two main categories, optical or ionisation .

Due to new European Directives for the storage and transport of radioactive sources, ionisation sensors are becoming less favourable and are being replaced by multi-sensors utilising single or dual optical chambers which are also combined with heat and/or carbon monoxide sensing elements.

This creates a whole range of sensors suitable for detecting different types of fires and yet ignore signals that previously have led to false alarms such as white dust or steam particles.

The table below shows the various 'states' of these smoke sensor options. This should be read in conjunction with the Sensor Application Guide to ensure the correct sensor is used for a particular location.

S-QUAD DUAL OPTICAL SMOKE SENSOR		
SENSOR	STATE	DESCRIPTION OF STATE SET UP
OHeat and O ² Heat	0	Medium Optical + A1 Heat
OHeat and O ² Heat	2	Low Optical + A1 Heat
OHeat and O ² Heat	3	High Optical + A1 Heat
OHeat and O ² Heat	5	Medium Optical + B Heat
OHeat and O ² Heat	6	Low Optical + BS Heat
OHeat and O ² Heat	8	Delayed Medium Optical + A1 Heat
OHeat and O ² Heat	11	Low Optical + B Heat
OHeat and O ² Heat	12	A1 Heat Only
OHeat and O ² Heat	15	All channels set to off

S-QUAD DUAL OPTICAL HEAT CO SMOKE SENSOR		
SENSOR	STATE	DESCRIPTION OF STATE SET UP
O ² Heat and CO	0	Medium Optical + A1 Heat + Medium CO
O ² Heat and CO	1	High Optical + A1 Heat + High CO
O ² Heat and CO	9	A1 Heat + Medium CO
O ² Heat and CO	11	B Heat + Medium Optical
O ² Heat and CO	12	A1 Heat only
O ² Heat and CO	15	ALL Channels set to OFF

Smoke detector spacing (under flat horizontal ceiling)

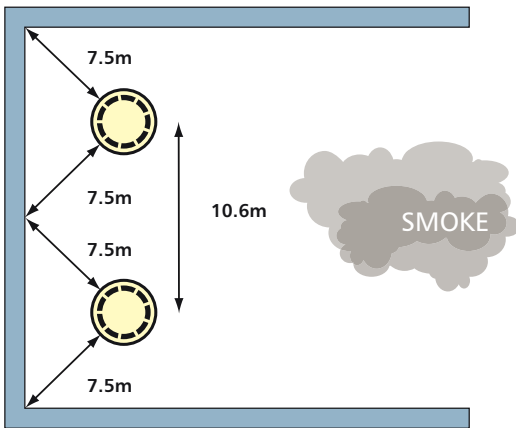

Smoke & Heat detector spacing in corridors (category P only)

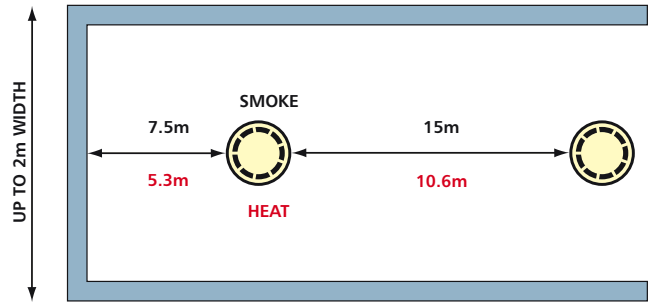

Smoke detector under pitched roofs

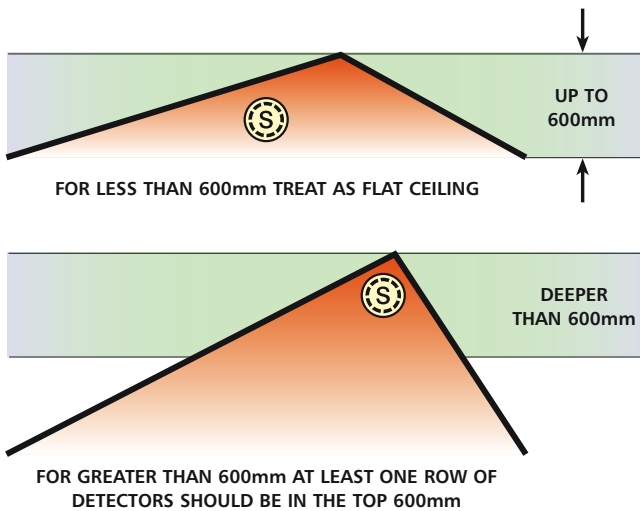

Mounting detectors in voids

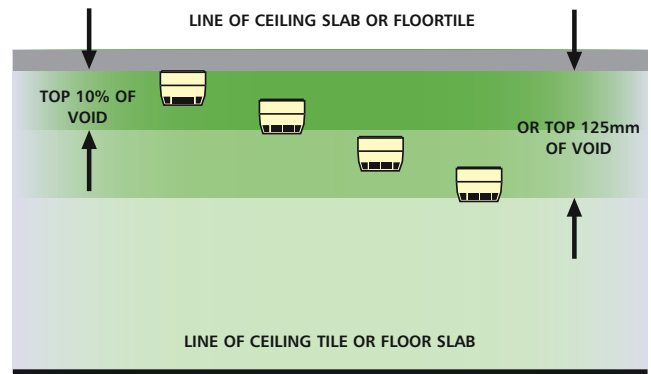

Applies to floor and ceiling void. Any of the above detector positions are acceptable

3: FIRE DETECTION & ALARM DESIGN

System Design

GENT
by Honeywell

Limits of siting sensors near obstacles or walls

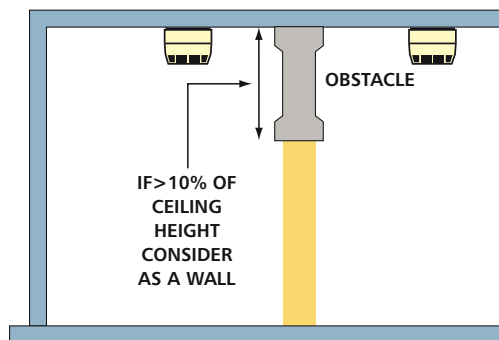
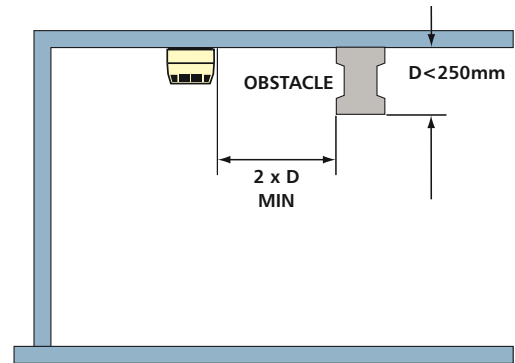
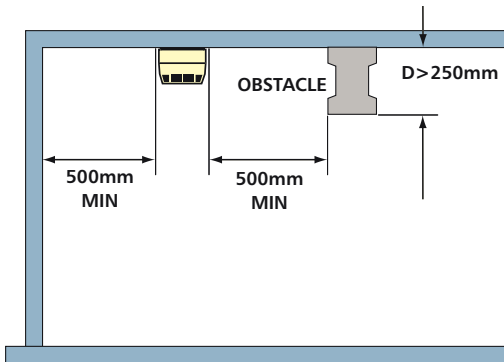

Siting sensors on ceilings with multiple joists

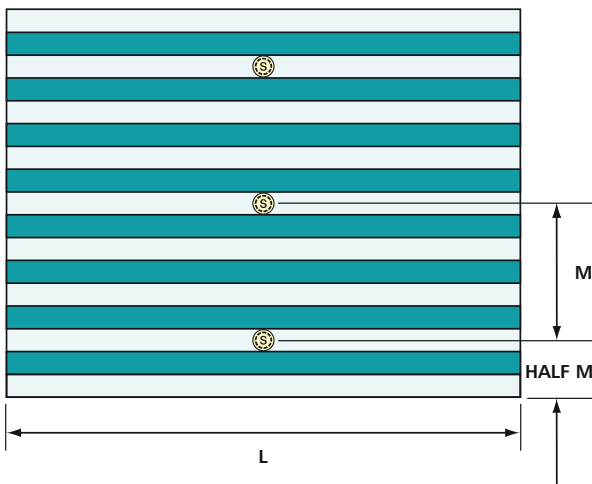

CEILING WITH MULTIPLE JOISTS			
CEILING HEIGHT (H)	BEAM DEPTH (D)W	SMOKE SENSOR SPACING (M)	HEAT SENSOR SPACING (M)
6m or less	Less than 10% H	5m	3.8m
More than 6m	Less than 10% H and 600mm or less	5m	3.8m
More than 6m	Less than 10% H and more than 600mm	5m	3.8m
3m or less	More than 10% H	2.3m	1.5m
4m	More than 10% H	2.8m	2.0m
5m	More than 10% H	3.0m	2.3m
6m or more	More than 10% H	3.3m	2.5m

Permitted spacing detailed in table below. Ratio between ceiling heights vs beam depth and maximum spacing 'M'.

Obstructions

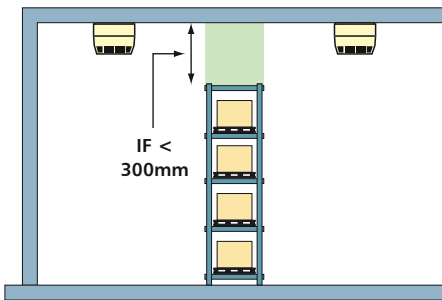

Ceilings above racking

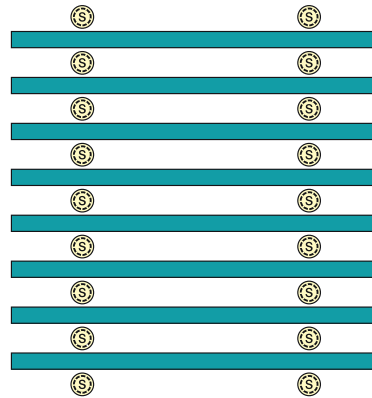

If gap between top of rack and ceiling is less than 300mm then treat as wall and provide detection in each aisle.

Ceilings with other obstructions or air handling units etc.

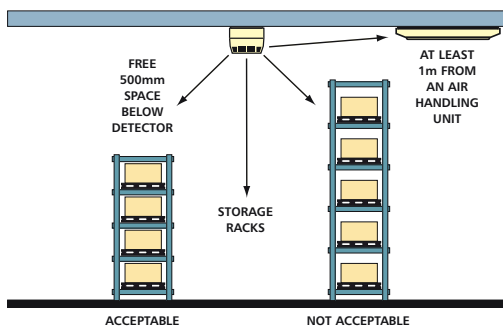

One of the most common mistakes is to mount a smoke sensor adjacent to the air conditioning intake or outlet grill. The minimum distance between the two should be at least 1 metre and further if possible. This is due to the fact that smoke may have difficulty penetrating the sensor when the air conditioning is switched on. Also there is a greater risk of the sensor becoming contaminated and giving rise to false alarms.

Ceilings above perforated ceilings

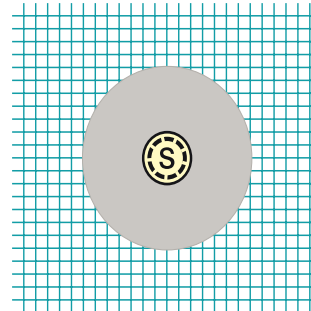
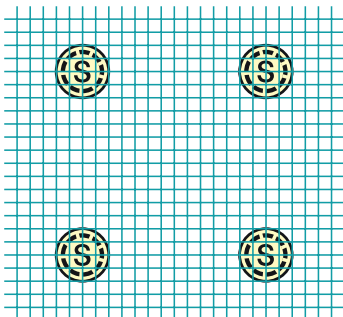

Detectors above ceilings with perforations can protect the area below subject to the following conditions

- The perforations are uniform
- The minimum perforation is > 10mm
- The thickness is < than 3 times the minimum dimension of the perforation

Where air is forced through a perforated ceiling, the detector should be mounted on a solid baffle with a minimum diameter of 1200mm

3: FIRE DETECTION & ALARM DESIGN

System Design

GENT
by Honeywell

Siting of beam detectors

ONE BEAM DETECTOR COVERS 17.5m USING EXTRA %
ALLOWED DUE TO ANGLE OF ROOF

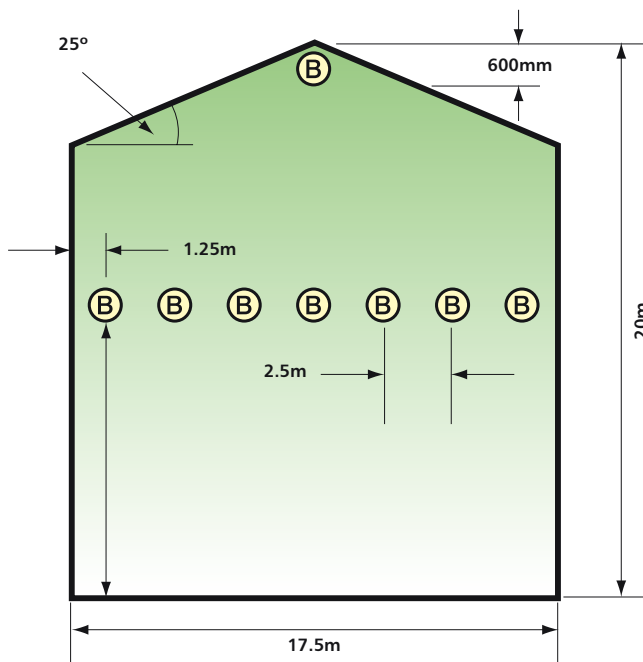

GAP BETWEEN DETECTORS 12.5% AND 25% OF 10m MOUNTING HEIGHT
= 1.25m AND 2.5m

- General rules apply as for point detectors
- For apex ceilings extend coverage by 1% for each degree of angle
- 600mm from the highest point
- Avoid beams close to walls (500mm) or where temporary obstructions may occur
- Mount transmitter and receivers on a solid surface not affected by wind or natural temperature changes
- Additional units may be included in atria to detect at lower levels, to counter stratification effect

Limits of ceilings heights (general)

DETECTOR TYPE	MAXIMUM	UP TO 10%
Heat detector – class A	9.0m	10.5m
Heat detector – other classes	7.5m	10.5m
Point type smoke detectors	10.5m	12.5m
Carbon monoxide detectors	10.5m	12.5m
Optical beam detectors	25.0m	25.0m
Aspiration – normal sensitivity	10.5m	12.5m
Aspiration – enhanced sensitivity	12.0m	14.0m
Aspiration – very high sensitivity	15.0m	18.0m

System Design

Design Stage 5 Choice and siting of alarm sounders and visual alarms

Sounders and strobes are generally provided for systems designed to protect life. However, on the rare occasion when only the property is being protected it is still essential to mount a sounder adjacent to the fire control panel as well as immediately outside the main entrance for the fire fighters.

Before deciding on the number and location of sounders/visual alarms, it is important to establish the 'Fire Plan' or cause and effect.

If the building is not going to have a 'one out – all out' arrangement, the evacuation procedures must be established. Once this is known, you can then establish the alarm zone areas where different alarm messages may be given, for example an alert or an evacuation tone.

Audible alarm levels within buildings are generally accepted as 65dB(A) throughout. However, the new Standard does accept that in certain locations this can be as low as 60dB(A). This allows some degree of flexibility, although in general the majority of a site must achieve 65dB(A) or greater to be compliant.

The drawing below illustrates the areas where 60dB(A) is permitted:

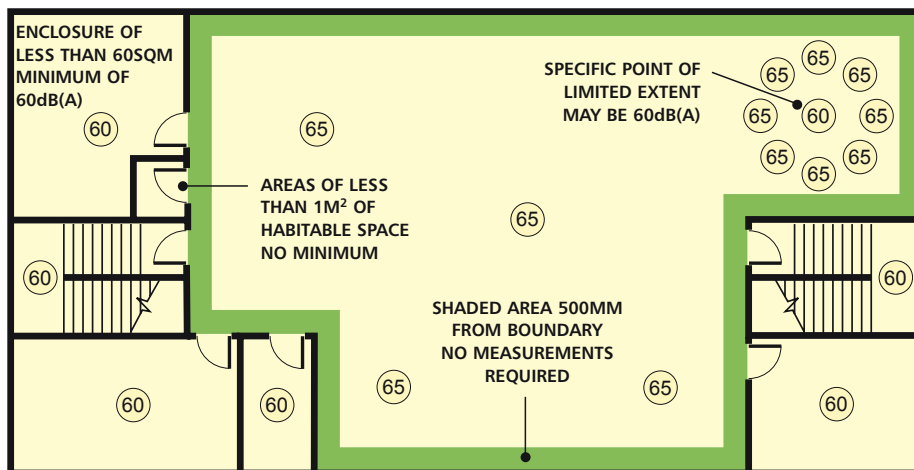

For areas with high ambient background noise levels, the Standard recommends a sound level of 5dB(A) above the norm although the maximum sound levels should not exceed 120dB(A) for health & safety reasons. Finally it is essential that at least one sounder is placed within each fire compartment and the sounder choice should be common throughout the building. Bells and electronic sounders should not be mixed within the same building although the Gent S-Cubed and S-Quad both offer bell and electronic sounders allowing a system upgrade or switch over from a bell tone to an electronic tone when required.

Design Tip 1 Research* over the last twenty years has proven that a voice enhanced sounder is preferable to a bell or electronic sounder as people pay more attention to a spoken message. The Gent S-Cubed and S-Quad offer sounders that include recorded speech messages delivered in a synchronised manner to create a clear instruction to persons at risk within a building.



* Sources: Brian Piggott (The Fire Research Station) and David Canter (Surrey University)

3: FIRE DETECTION & ALARM DESIGN

System Design

GENT
by Honeywell

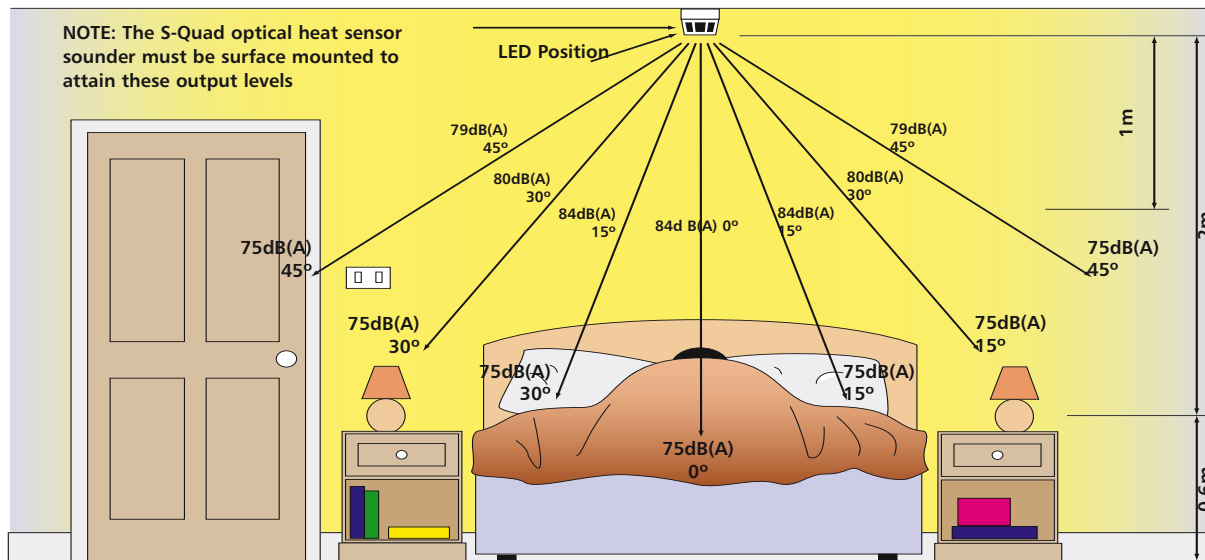

It is maintained that to rouse sleeping persons you need to achieve a minimum of 75dB(A) at the bedhead.

Sound attenuation is affected by numerous physical structures within a room, including the people, door, furniture and materials used for floor, walls etc.

General internal doors will attenuate at least 20dB(A), whilst heavier fire doors may well attenuate by up to 30dB(A). To ensure 75dB(A) is achieved within a bedroom it is accepted that the sounder is mounted within the room rather than the corridor outside. Use of sensor sounders ensures an even spread of sound throughout the building without the need for separate louder sounders. Visual alarms are generally considered as supplementary rather than the only means of providing an alarm, and are used in areas where the dB(A) level exceeds 90dB(A) or where persons within the area have impaired hearing. The exception could be where sound of any description is undesirable, for example operating theatres, TV studios and places of entertainment where a discreet staff alarm system is the best option to avoid panic.

Visual alarms are also included as a requirement of the Disability Discrimination Act and Approved Document M of the Building Regulations and should be included in all sleeping accommodation where people with a hearing disability may be present.

Design Stage 6 Control equipment and power supplies

The Control panel itself should comply to EN54-2 and any power supply used should comply to EN54-4. Today the majority of Gent fire control panels incorporate their own battery and charger and as long as the guidelines for loading these systems are complied with, the battery should be sufficient to maintain the system for a period of 24 hours with half an hour alarm load thereafter.

It is however recommended that a battery load calculation is carried out to verify the standby period provided by the capacity of the battery supplied.

Irrespective of the size or type of system the control panel should be sited with the following points in mind;

- In an area of relatively low fire risk
- On the ground floor entrance which the fire fighters will use
- In buildings of multiple occupancy, the panel should be sited within a communal area or if this does not exist, a location which is accessible at all times
- Where ambient light levels, ensure visibility at all times
- Fire zonal indication should be clearly displayed by LEDs or an illuminated mimic diagram – it is not acceptable to simply accept the information from an LCD or VDU display

If there are several entrances to the building, consideration should be given to the provision of repeat indicators.

Design Tip 2 The S-Quad combines a sounder and strobe within a sensor which not only reduces the number of individual devices you have to install, but also provides an even cover of sound and light throughout a building.



The Installers' responsibilities

- To install all equipment in accordance with the Standard
- To use the correct types of cable
- To test the cables, continuity and earth, and provide certificates
- To flag up any Variations that affect the Design
- To produce a set of 'as fitted' drawings
- To sign off a G2 Installation certificate

Types of cable and where to use them

There are two basic grades of cable permitted for use on fire alarm systems. These are known as Standard grade and Enhanced grade designed to meet the new standards BS 8434-1 and BS 8434-2 respectively.

The choice of cable needed is dependant on how long the cable is expected to continue to operate whilst a fire is occurring.

The integrity of the system is paramount and all interconnections between devices must be considered especially those that affect the signal's critical path.

Firstly the Standard insists that the mains supplies to the system, the manual call points and the automatic sensor circuits are wired in fire resistant cables.

What cable? – Standard or Enhanced fire resistant cables?

The Standard fire resistant cable will satisfy most applications particularly with 'one out, all out' fire plans. Enhanced fire resistant cables are required for applications that need communications to continue during a fire incident when the building fabric may be destroyed. Examples of where Enhanced fire resistant cable should be used include:

- In un-sprinklered buildings where the 'Fire Plan' involves the evacuation of occupants in four or more phases
- In un-sprinklered buildings greater than 30 metres in height
- In un-sprinklered buildings or large networked sites where a fire could affect the cable's 'critical path', particularly where people will remain in occupation during a fire elsewhere on the site
- Where in part, a delayed evacuation may exist and the critical signal path may pass through an area of high risk
- Where a Risk Assessment has identified a particular need for Enhanced cable

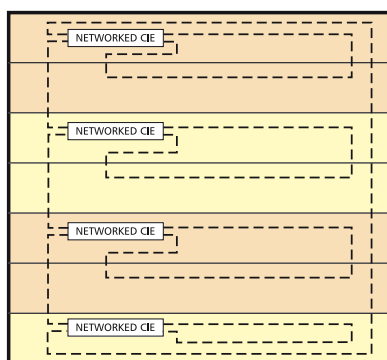

Standard Fire Resisting Cable

Example of a networked fire alarm in a multi-storey building, showing standard cable grade throughout provided that there is diverse routing of the network cable loop.

Sixth Floor
Fifth Floor
Fourth Floor
Third Floor
Second Floor
First Floor
Ground Floor

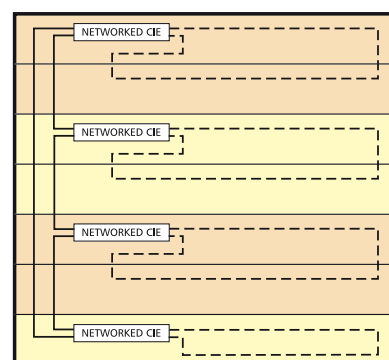

Standard Fire Resisting Cable

Enhanced Fire Resisting Cable

Example of a networked fire alarm in a multi-storey building, showing standard cable grade for local wiring and enhanced grade for network cable.

3: FIRE DETECTION & ALARM DESIGN

System Installation

GENT
by Honeywell

Other aspects in regard to Installation practice

- The electrical characteristics of the cable such as impedance, capacitance etc should be capable of handling the data and power of the system.
- For the Vigilon system, Gent regularly updates the list of approved standard and enhanced cables used for loops or networks. We would suggest you obtain the latest copy of our system data sheets or contact your local engineer to obtain the latest approved product.

Cable requirements

- Core size not less than 1mm
- Where exposed cables are below 2m, additional mechanical protection should be considered, except for cables complying to BS 7629
- The colour of the outer sheath should preferably be RED although other colours are permitted as long as it is common throughout the building and does not clash with any other electrical services

Fire cables should:

- be segregated from all other services
- not share the same conduit
- use a separate compartment if common trunking is used
- avoid running alongside high current power lines
- avoid running adjacent to lightning conductors
- avoid electro magnetic interference from 'extra low voltage (240V) circuits'
- The Standard precludes the use of multicore cable where a single fault will cause more than one circuit to fail. This is particularly true with loop wired systems where communication from either end is required and the failure of a 4-core cable will mean that all communication is lost
- Cable joints should be avoided, other than the components themselves
- Cable support should withstand the same temperature as the cable, which means the use of plastic cable clips, cable ties or trunking, where this is the main means of supporting the cable, should NOT be used
- Cables should not rely on suspended ceilings for their support
- Mains power supplies should also be wired back to the main circuit breaker in Standard grade fire resistant cable

Recommendations for the Mains Power supplies

For reasons of electrical safety, the mains supply to the system should be via a separate circuit breaker taken from the load side of the buildings main isolating device.

This circuit breaker can incorporate a switch if necessary but in either event should be labelled 'FIRE ALARMS – DO NOT SWITCH OFF' – this supply should be used for the sole purpose of the fire alarm system.

In large multiple occupancy buildings it may be necessary to obtain a mains supply via a mains distribution board. However the same arrangements as above apply. The isolation of this local distribution board and the fire isolating device is a minimal requirement and should be inaccessible to unauthorised persons.

Ideally the supply should not be protected by a residual current device unless necessary to comply with requirements of BS 7671. If this is the case then it should not be capable of isolating the mains supply to the fire alarm system.

Inspection and testing of wiring

Prior to any equipment being connected, all installed cables should be subject to a 500V dc insulation test.

These tests should show an insulation value of at least 2Mohm between conductors and between each conductor and screen or earth.

Earth continuity tests should be carried out on all mains supply circuits as well as an earth loop impedance in accordance with BS 7671. It is important with the Vigilon system that all earth leads or screen cables are terminated and connected through each device.

The maximum impedance of each loop or radial circuit should be recorded to ensure it meets the manufacturers recommendations. In the case of Vigilon this is determined by not exceeding the recommended maximum cable lengths which for loop circuits should not be greater than 1Km and a maximum of 100metres for any radial circuit connected on a loop powered interface.



Commissioning Engineers' responsibilities:

- Functional testing of all equipment
- Confirm fire plan or cause & effect is correct as per design
- Look for any incorrect positioning of sensors or other devices – snag them or list them as Variations
- Record sound level meter readings
- Provide a log book and product manuals
- Carry out staff training
- Collate all documents including
 - G1 Design Certificate
 - G2 Installation Certificate
 - G3 Commissioning Certificate (also sign it!)
 - Cable test and wiring certificate
 - Specification and drawings
 - List of agreed Variations
 - Fire Plan or 'Cause and Effect'
 - G4 Acceptance Certificate signed by clients representative

It is important that the system is commissioned by a competent person who has attended recognised training courses on the equipment as well as the British Standard.

At this stage the entire system should be inspected and tested, in particular;

- Every manual call point, sensor, sounder, interface and indicator
- Check that all devices are correctly sited to cover the area they are intended to protect – see previous notes on siting of devices
- Check that all devices are correctly labelled and display the correct information on the control panels
- All sound pressure levels should be measured and recorded
- Any transmission of signals to remote centres or equipment should be proven
- The fire plan or cause and effect should be checked from every device
- All alarm panels and printers display the correct information and are sited correctly
- A suitable zone plan is mounted adjacent to the control panel
- No changes to the building have affected the siting of equipment or effectiveness of the system for example an additional partition requiring additional sensors
- Mains and standby power supplies are adequate and designed to support the system for a specified period, for example 24, 48 or 72 hours
- As far as reasonable, ascertain that the installation complies with the standard and certificates are provided by the installer
- If radio equipment is used, ensure all radio signals are of sufficient strength to ensure reliability
- Ensure there are no obvious shortcomings with the system as a whole and that all the documentation is correct

It is also recommended that the system is soak tested for up to a week, dependant on the system size, so that any teething problems are identified without giving rise to any false alarms.

Documentation

On completion of commissioning and user training all documentation will have to be collected and handed to the client or their representative. This will include;

- Design, Installation and Commissioning certificates G1,G2 & G3
- Cable and insulation resistance test records
- "As fitted" drawings of the final installation, including cable run details
- Product manuals and user instructions
- System log book
- A copy of the fire plan documentation against which the commissioning engineer programmed the system
- The designer's specification and a written list of agreed Variations

3: FIRE DETECTION & ALARM DESIGN

Sensor Application Guide

GENT
by Honeywell

This guide is aimed at providing advice on the most suitable type of sensor for specific applications. Obviously conditions may vary depending on the particular application and if there are any doubts we suggest you consult one of our field sales advisors.

GENERAL APPLICATION FOR SENSOR	PREFERRED OPTION	OPTION 2	OPTION 3	OTHER SOLUTIONS
Air extraction ducts	Duct detectors	Aspiration		
Airport terminals	Beams** state 0	O ² H* state 0	Video	
Animal houses, stables, zoo's etc	EP heat state 0			
Areas of High risk like Historic Houses	Aspiration	O ² HCO* state 1	Radio detection	Suggest time out feature, used when reduced sensitivity is required
Atria	Beams** state 0	Aspiration Vertically		Note use 'snout' on receivers to protect against sunlight
Battery re-charge rooms	O ² H* state 0	Flame		
Bedroom	O ² H* state 0	O ² H* state 8		
Bedroom with adjacent Bathroom	O ² H* state 8	O ² HCO* state 0	O ² HCO* state 9	Options dependant on severity of steam leakage into bedroom see table 2
Bedroom with bath & or kitchen attached	O ² H* state 8	O ² HCO* state 0	O ² HCO* state 9	Options dependant on severity of steam cooking fumes leakage into bedroom see table 2
Boiler room with coal or coke	H* state 5	O ² HCO* state 11		
Boiler room clean with Gas/Oil/Electrical source	O ² H* state 5	O ² HCO* state 11		
Cable duct ways	Linear Heat	Beams** state 0		Watch out for obstructions for options 2
Car park (enclosed)	H* state 0	O ² H* state 2	O ² H* state 8	
Changing rooms alongside showers etc	O ² HCO* state 9	H* state 0		
Clean data processing room	O ² HCO* state 1	O ² H* state 1	Aspiration	Watch for rapid air changes see table 2
Cold rooms	Aspiration			Use heat state 0 but avoid fitting near open doors
Corridors, stairwells or internal passageways	O ² H* state 0			
Electrical switch or plant rooms	O ² HCO* state 0	O ² H* state 0		
Enclosures open to air	EP Heat	EP Flame		
Flour Mills	O ² HCO* state 9	Flame detector		
Garage work areas	H* state 0	O ² HCO* state 9	O ² H* state 2	Suggest timeout feature to revert to O ² HCO* state 0
Kitchen large commercial	H* state 6	O ² HCO* state 11		Suggest timeout feature revert to higher detection state 0 or 9 respectively
Kitchen small domestic	O ² H* state 2	H* state 13		
Laundry room large, high ceiling	Beams** state 0	O ² HCO* state 9	Flame	Consider linear heat around machinery
Laundry room small, low ceiling	O ² HCO* state 9	H* state 13		
Laundry Storage room	O ² HCO* state 9	H* state 0		
Libraries	O ² HCO* state 0	Aspiration	O ² H* state 0	
Normal office or working area	O ² H* state 0			
Open high ceilings in Churches or Cathedrals	Beams** state 0	Flames		Watch number of candles lit for option 2
Restaurant area	O ² H* state 0	H* state 0		Suggest timeout feature to switch between states
Retail shop High ceilings (e.g. B&Q)	Beam state 0			
Retail shop Normal ceiling height	O ² H* state 0	O ² HCO* state 0		
Room with gas fire	O ² H* state 0	O ² HCO* state 0		
Room with Open wood/coal fire	O ² H* state 2	H* state 0		
Scientific Laboratories	O ² HCO* state 0			Wide variation dependant on use contact engineer
Spray booths - spray shops	Flame	H* state 0	Linear Heat	Watch out for hazardous requirement
Steam rooms, sauna or shower areas	EP heat	O ² HCO* state 9		
Store rooms	O ² HCO* state 0			Subject to material in store
Tunnels	Flame	Linear Heat		
Warehouse	Beams** state 0	O ² H* state 0		Option 1 watch out for fork lift trucks & cranes
Warehouse loading bay	H* state 0	Flame	O ² H* state 0	
X-ray or other high EMC areas	Aspiration	O ² HCO* state 0		Ignore use of ionisation detectors

Note* Versions may include Speech, Sound and strobe or mixture of all features. ** Beams state dependant on path length.

Choice and siting of automatic sensors

This table provides guidelines on the type of sensor and programmable 'state' of those sensors, that should be used when specific risks are present. The solutions that are listed are chosen to provide optimum performance for detecting fire and minimising the risk of false alarms. In most cases the sensor 'states' can be preset at selected time frames and therefore revert back to a more sensitive 'state' for normal protection level shown on the application table.

SPECIFIC RISK	PREFERRED SOLUTION	OTHER OPTIONS OR ADVICE
Aerosol (excessive)/Chemicals	Flame	HCO may be suitable depending on aerosol
Aerosol (general)	O ² H state 8 or O ² HCO state 0	If possible use Timezone disablement on O ²
Burning toast/food	H state 13 or O ² HCO state 9	This is a FIRE therefore manage with techniques such as Timezone disablement on O ²
Cigarette smoke (excessive)	O ² HCO state 9	If possible use Timezone disablement on O ² . Could give an alarm with high levels of CO (See note 1)
Cooking fumes	O ² HCO state 9	If possible use Timezone disablement on O ²
Direct sunlight	O ² HCO state 0	Fit snouts to beam detector receivers. Other sensors may be used including CO. May delay detection of fire with optical sensors because of thermal barrier effect. Avoid use of Flame detectors.
Dry Ice (CO ₂)	O ² HCO state 9	All optical sensors are unsuitable
Dust (temporary eg. Builders clear up period)	Fit dust covers to sensors	Remove sensors altogether
Dust or lint (excessive)	O ² HCO state 9 or Flame	All optical sensors are unsuitable
Fork lift trucks & Cranes		Watch out when using beam detectors
Fire appliance - gas (clean burning)	O ² H state 0	See Rapid temperature changes
Fire appliance - wood, coal, coke or flame effect gas	O ² H state 8	See Rapid temperature and dust. do not use Flame or CO
Fumes for hot oil based machines (suds etc)	O ² HCO state 9	All optical sensors are unsuitable
Gas (battery charging, animal house)	O ² H state 0	CO sensors are unsuitable
High humidity (up to 95% RH)	O ² H state 0	Generally OK for all types, if humidity levels are constant. Continuous operation in high humidity environments may reduce the life expectancy of the sensor
High powered electro- magnetic equipment	O ² H state 0	Avoid placing detectors or FDA cables near equipment (X-ray machines, scanners etc)
Insect & harvest flies	O ² HCO state 0 or 9	Excessive infestation of insects may cause a delayed response in O ² H as it can reduce the sensitivity of the optical
Low humidity (less than 15% RH)	O ² H state 0	CO sensors should not be used in continuously dry environments
Rapid air changes	O ² H state 0	May delay detection dependent on location and direction/speed of air flow. Aspiration detection is an alternative
Soldering	O ² HCO state 9	If possible use Timezone disablement on O ²
Spiders (small)	O ² HCO state 9	All optical sensors including beams are unsuitable
Steam or water vapour (excessive/ constant)	O ² HCO state 9	All optical sensors are unsuitable
Steam or water vapour (occasional/light)	O ² HCO state 0	O ² will withstand quite high levels, O ² may have delayed action
Temperature - high ambient	H state 5 or O ² H state 5	Suitable range 40°C to 65°C
Temperature - low (permanently below 0°)	Aspiration detectors	Use Heat state 0 but avoid fitting near open doors
Temperature - rapidly changing	H state 13	Fixed temperature operation only
Vehicle exhausts (occasional)	O ² HCO state 9 or O ² H state 8	Could give an alarm with high levels of CO (See note 1)
Welding or brazing	H state 13 or O ² H state 8	Type of welding must be known before selecting other sensor type

Note:

- 1 High levels of CO could cause physical damage to occupants therefore alarm is desirable but CO elements should not be relied on for sensing gas leaks.
- 2 Heat detectors configured to state 0 are suitable for all risks unless otherwise indicated.
- 3 An O²H device should always be used in preference to an OH, where a specific unwanted alarm risk could occur.